



MANUFACTURING | AUTOMATION | CALIBRATION

+91 9082554415 / 9022709337

info@preciseequipments.com



ALL CUSTOM PRODUCTS ARE DESIGNED TO  
ASME SECTION VIII DIV.1 CURRENT EDITION



- ✓ **Fabricated Basket Strainer**
- ✓ **Duplex Basket Strainer**
- ✓ **Self Cleaning Filter**
- ✓ **Duplex Strainer With Backwash System**
- ✓ **Basket Strainer With Air Eliminator**
- ✓ **Magenatic Filter**
- ✓ **Y Type Strainer**
- ✓ **T Type Strainer**
- ✓ **Temporary Strainer**

**HIGH QUALITY STRAINER FOR YOUR  
WORLD CLASS EQUIPMENT**

[www.preciseequipments.com](http://www.preciseequipments.com)

# FABRICATED BASKET STRAINER



Basket strainer feature top removal of the screen. the screen is in the form of a basket. inside the strainer is a mesh, which block any suspended impurities that the fluid has and is collected in the mesh, during maintenance the mesh can be removed and cleaned of the impurities.

They are intended for application where large amount of solid particles are expected and where the clean-out will be frequent. for easily flushable solids, a modified cone bottom basket can be fitted with automatic or manual blow-down through drain port. this will allow clean-out without removal of the screen, and without interrupting the flow process.

## APPLICATIONS :

- ✓ Pump Protection
- ✓ Flow Meter Protection
- ✓ Valves & Regulator Processes
- ✓ Protection Of Heat Exchanger And Refrigeration
- ✓ Instrumentation And Piping Item Protection

## CONSTRUCTION

IT. NO.	DESCRIPTION	MATERIAL	QTY.
14	GASKET	PTFE/AF-120/SPIRAL WOUND	1
13	VENT PLUG	M.S/SS304/SS316/SS304 L/SS316L	1
12	DRAIN PLUG	M.S/SS304/SS316/SS304 L/SS316L	1
11	NUTS BOLTS	M.S/SS304/SS316	-
10	LIFTING HOOK	M.S/SS304/SS316/SS304 L/SS316L	1
9	FILTER HANDLE	M.S/SS304/SS316/SS304 L/SS316L	1
8	RING	M.S/SS304/SS316/SS304 L/SS316L	1
7	FILTER ELEMENT	SS304/SS316/SS304 L/SS316L	1
6	BOTTOM FLANGE	M.S/C.S/SS304/SS316/SS304 L/SS316L/PP	1
5	TOP FLANGE	M.S/C.S/SS304/SS316/SS304 L/SS316L/PP	1
4	SHELL FLANGE	M.S/C.S/SS304/SS316/SS304 L/SS316L/PP	1
3	PROCESS FLANGE	M.S/C.S/SS304/SS316/SS304 L/SS316L/PP	2
2	PROCESS PIPE	M.S/C.S/SS304/SS316/SS304 L/SS316L/PP	2
1	SHELL PIPE	M.S/C.S/SS304/SS316/SS304 L/SS316L/PP	1

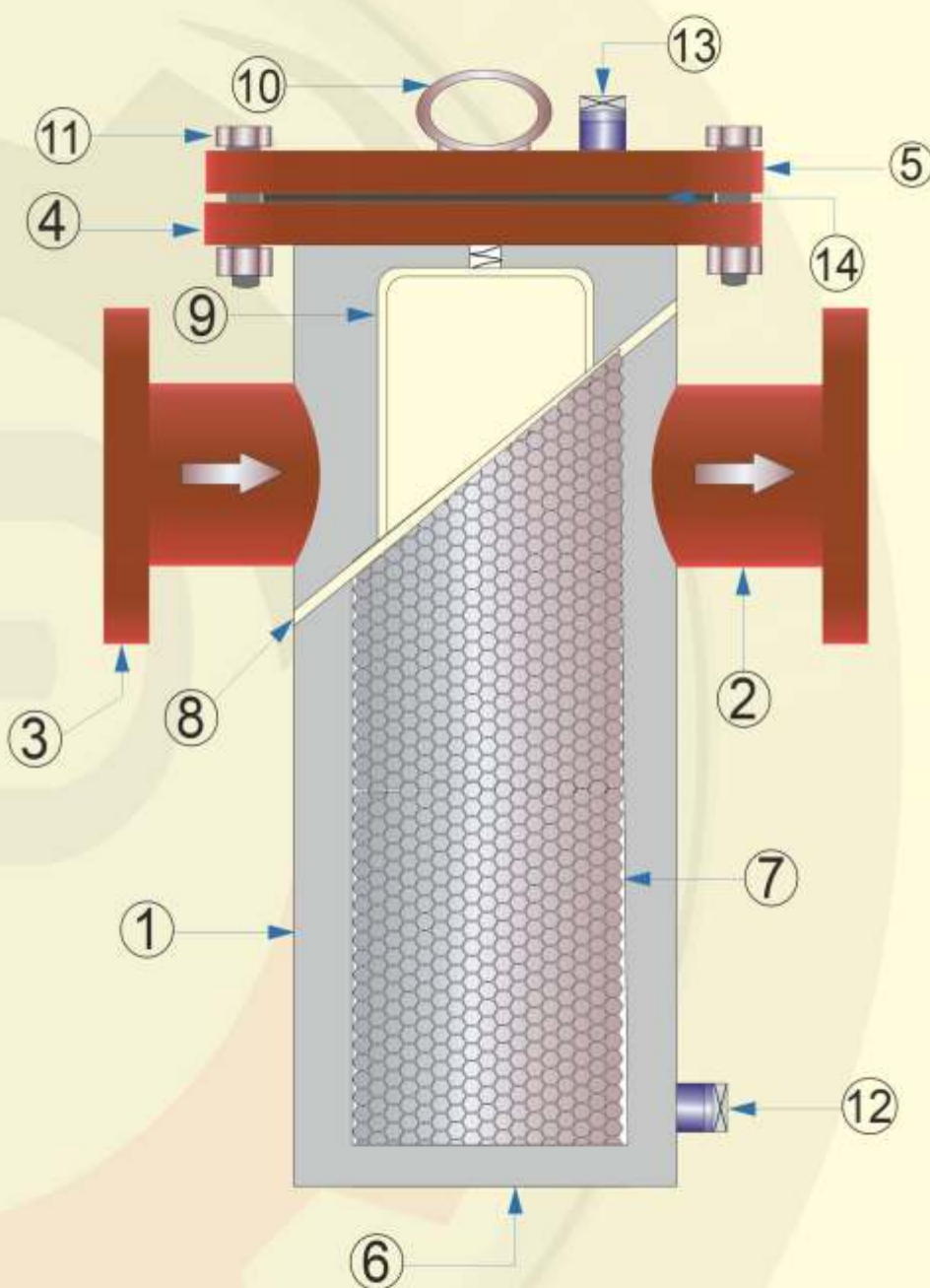

## DIMENSIONS IN MM

NB	A	B	C	D	E	F	G	SHELL ID
25	205	115	75	48	78.5	27	110	40.9
40	240	145	83	60.3	90	40	150	52.5
50	275	195	93	88.9	93	50	205	77.9
65	320	115	105	101.6	109	65	240	90.1
80	350	245	115	114.3	118	80	270	102.3
100	380	275	130	141.6	120	100	310	102.3
150	445	300	160	219	113	150	360	206.4
200	525	376	190	273	126	200	460	260.4
250	625	390	235	323	151	250	500	311.2
300	650	440	300	355	147.5	300	575	339.8
350	800	625	318	406	197	350	785	390.6
400	800	730	390	457	171	385	900	447.6
450	850	825	325	508	171	450	1035	495
700	1250	1085	550	762	244	670	1415	747.7

